

# High Efficiency Power Supply for Small Size Displays

## ISL98607

The ISL98607 is a high efficiency power supply for small size displays, like smart phones, requiring  $\pm$ supply rails. It integrates boost regulator, LDO, and inverting charge pump that are used to generate two output rails: +5V (default) and -5V (default). The  $\pm$ 5V output voltages can be adjusted up to  $\pm$ 5.7V with 50mV steps using the I<sup>2</sup>C interface.

The device integrates synchronous rectification MOSFETs for the boost regulator and inverting charge pump, which maximizes conversion efficiency.

ISL98607 integrates all compensation and feedback components, which minimizes BOM count and reduces the solution PCB size to 21mm<sup>2</sup>.

The input voltage range, high efficiency operation, and also very low shutdown current make the device ideal for use in single cell Li-ion battery operated applications.

The ISL98607 is offered in a 1.82x2.15mm<sup>2</sup> WLCSP package, and the device is specified for operation over the -40°C to +85°C ambient temperature range.

## Features

- Two outputs:
  - VP = +5.0V (default)
  - VN = -5.0V (default)
- 2.8V to 4.4V Input voltage range
- >85.5% Efficiency with 12mA load between VP and VN
- 21mm<sup>2</sup> Solution PCB area
- Fully integrated FETs for synchronous rectification
- Integrated compensation and feedback circuits
- I<sup>2</sup>C adjustable output voltages and settings
- Integrated VP/VN discharge resistors
- 1 $\mu$ A shutdown supply current
- 1.82x2.15mm, 4x5 array WLCSP with 0.4mm pitch
- Pb-Free (RoHS compliant)

## Applications

- TFT-LCD Smart phone displays
- Small size/handheld displays

## Typical Application

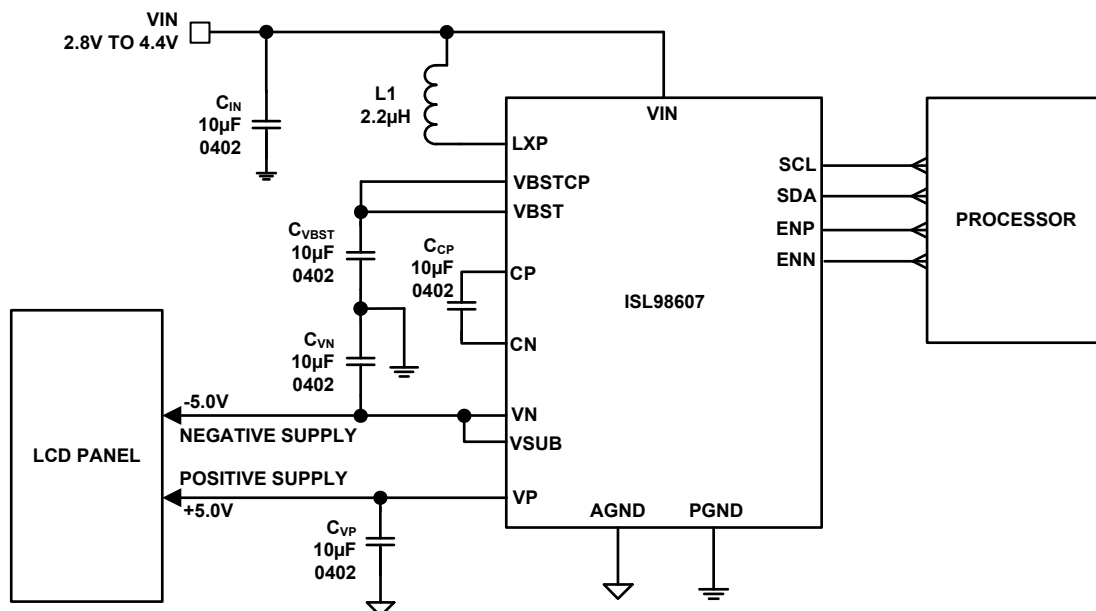

FIGURE 1. TYPICAL APPLICATION CIRCUIT: TFT-LCD SMART PHONE DISPLAY

For additional products, see [www.intersil.com/en/products.html](http://www.intersil.com/en/products.html)

---

Intersil products are manufactured, assembled and tested utilizing ISO9001 quality systems as noted in the quality certifications found at [www.intersil.com/en/support/qualandreliability.html](http://www.intersil.com/en/support/qualandreliability.html)

---

*Intersil products are sold by description only. Intersil Corporation reserves the right to make changes in circuit design, software and/or specifications at any time without notice. Accordingly, the reader is cautioned to verify that data sheets are current before placing orders. Information furnished by Intersil is believed to be accurate and reliable. However, no responsibility is assumed by Intersil or its subsidiaries for its use; nor for any infringements of patents or other rights of third parties which may result from its use. No license is granted by implication or otherwise under any patent or patent rights of Intersil or its subsidiaries.*

---

For information regarding Intersil Corporation and its products, see [www.intersil.com](http://www.intersil.com)